

NOTES:

1. SECURITY JUNCTION BOX (SJB) SHALL BE 4x4 WITH SINGLE GANG MUD RING MOUNTED HORIZONTAL.
2. ALL INFRASTRUCTURE (ENCLOSURES, CONDUIT, ETC) TO BE PROVIDED BY CONTRACTOR.
3. DOOR HEADER CONDUIT SHALL BE STUBBED TO JUST ENTER HEADER FRAME 3" TO 4" FROM OPENING SIDE OF DOOR.

NOTES:

1. THIS INSTALLATION DETAIL SHALL BE UTILIZED FOR ALL SECURITY DOORS.
2. ALL ELECTRICAL AND DATA WIRING SHALL BE IN CONDUIT PER CSU STANDARDS.
3. DRAWING NOT TO SCALE.

<b>Colorado State University</b>		DRAWING:
FACILITIES PLANNING, DESIGN AND CONSTRUCTION STANDARDS		A-1A
DATE: 03/04/2021		OPENINGS DIV. 08
<b>DOUBLE DOOR</b>		

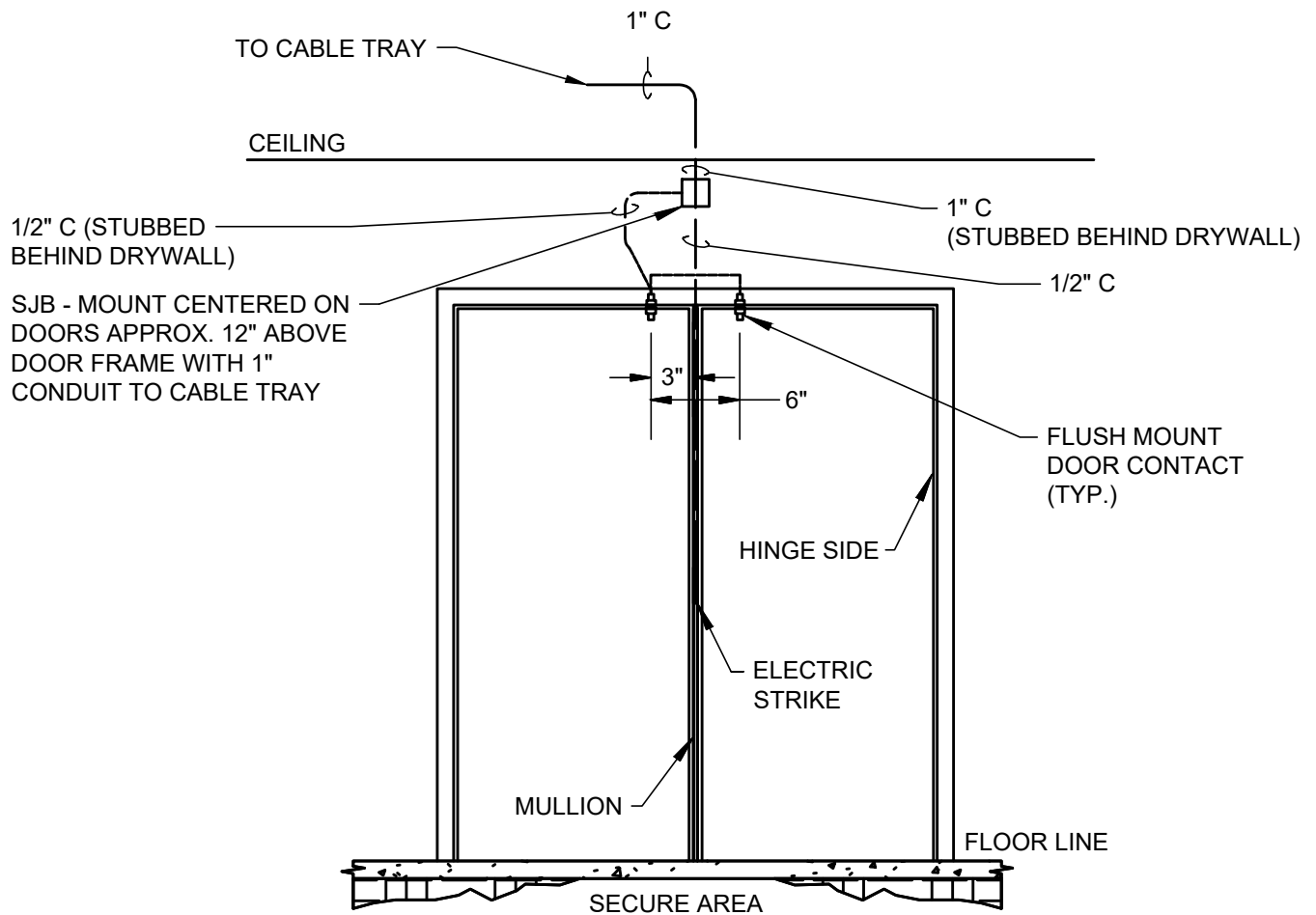

**NOTES:**

1. SECURITY JUNCTION BOX (SJB) SHALL BE 4x4 WITH SINGLE GANG MUD RING MOUNTED HORIZONTAL.
2. ALL INFRASTRUCTURE (ENCLOSURES, CONDUIT, ETC) TO BE PROVIDED BY CONTRACTOR.
3. DOOR HEADER CONDUIT SHALL BE STUBBED TO JUST ENTER HEADER FRAME 3" TO 4" FROM OPENING SIDE OF DOOR.

**NOTES:**

1. THIS INSTALLATION DETAIL SHALL BE UTILIZED FOR ALL SECURITY DOORS.
2. ALL ELECTRICAL AND DATA WIRING SHALL BE IN CONDUIT PER CSU STANDARDS.
3. DRAWING NOT TO SCALE.

<b>Colorado State University</b> FACILITIES PLANNING, DESIGN AND CONSTRUCTION STANDARDS	DRAWING: <b>A-1B</b>
	OPENINGS DIV. 08
DATE: 03/04/2021	
<b>DOUBLE DOOR WITH ELECTRIC STRIKE</b>	

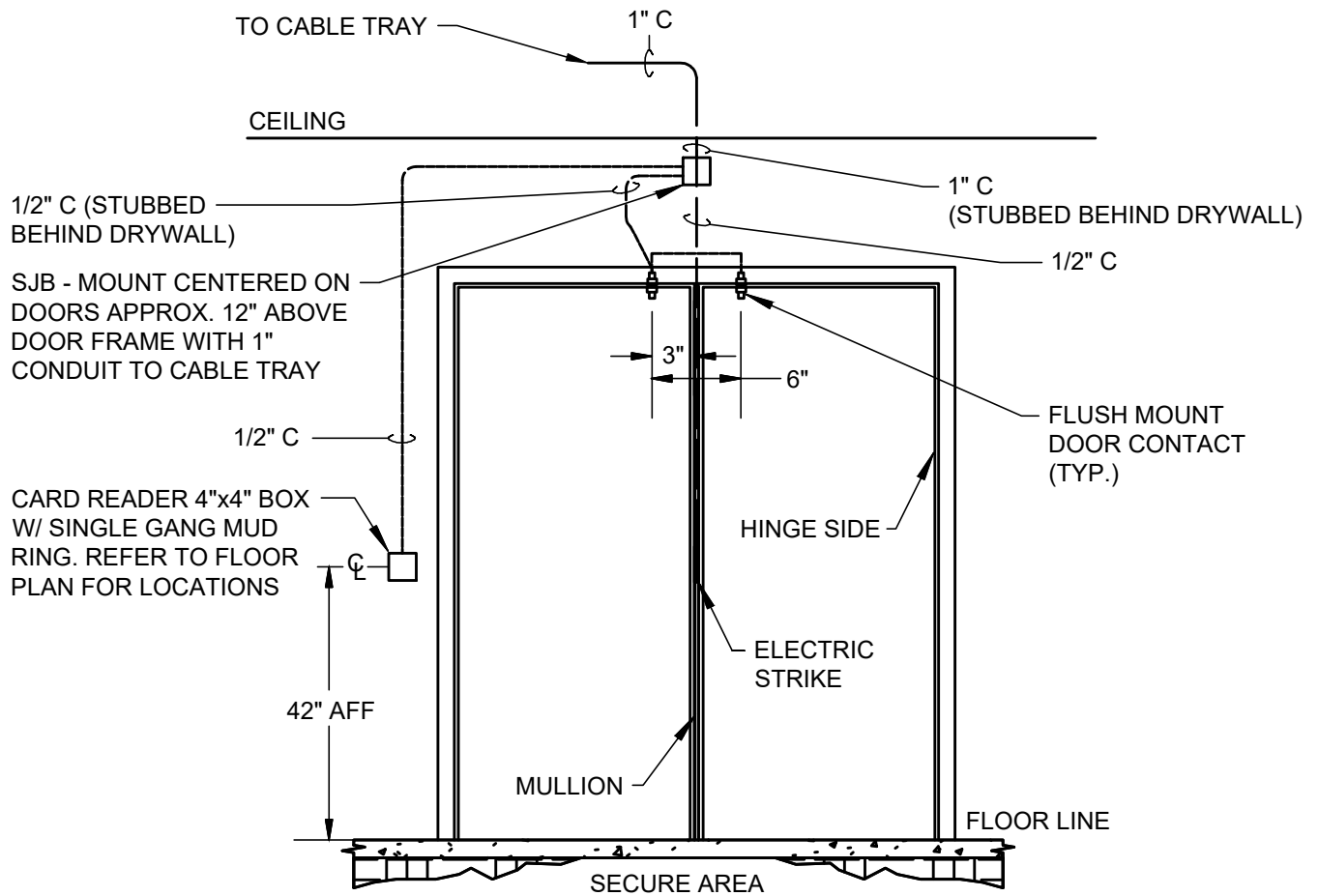

**NOTES:**

1. SECURITY JUNCTION BOX (SJB) SHALL BE 4x4 WITH SINGLE GANG MUD RING MOUNTED HORIZONTAL.
2. ALL INFRASTRUCTURE (ENCLOSURES, CONDUIT, ETC) TO BE PROVIDED BY CONTRACTOR.
3. DOOR HEADER CONDUIT SHALL BE STUBBED TO JUST ENTER HEADER FRAME 3" TO 4" FROM OPENING SIDE OF DOOR.

**NOTES:**

1. THIS INSTALLATION DETAIL SHALL BE UTILIZED FOR ALL SECURITY DOORS.
2. ALL ELECTRICAL AND DATA WIRING SHALL BE IN CONDUIT PER CSU STANDARDS.
3. DRAWING NOT TO SCALE.

<b>Colorado State University</b> FACILITIES PLANNING, DESIGN AND CONSTRUCTION STANDARDS	DRAWING: <b>A-1C</b>
	OPENINGS DIV. 08
DATE: 03/04/2021	
<b>DOUBLE DOOR WITH ELECTRIC          STRIKE AND CARD READER</b>	

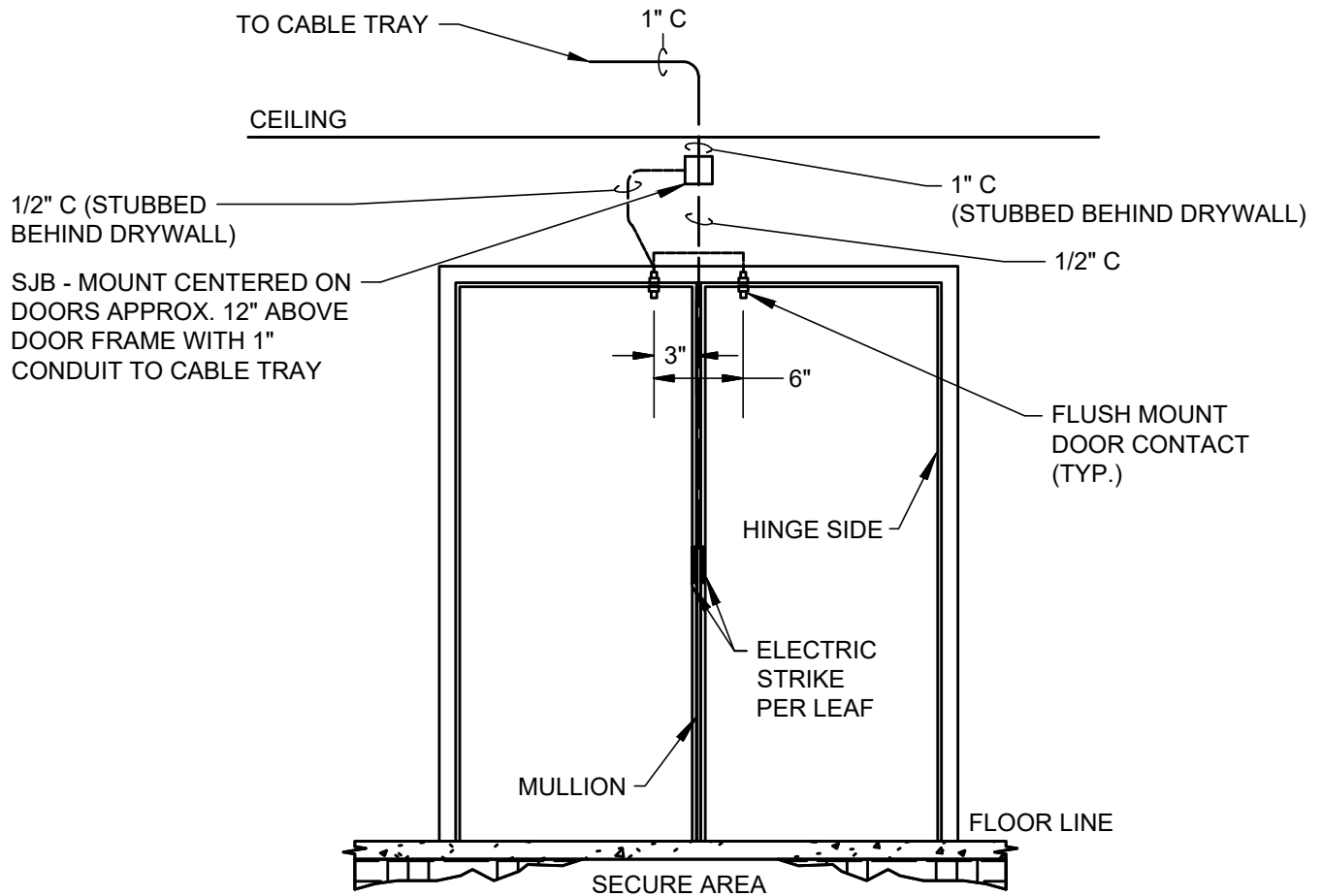

NOTES:

1. SECURITY JUNCTION BOX (SJB) SHALL BE 4x4 WITH SINGLE GANG MUD RING MOUNTED HORIZONTAL.
2. ALL INFRASTRUCTURE (ENCLOSURES, CONDUIT, ETC) TO BE PROVIDED BY CONTRACTOR.
3. DOOR HEADER CONDUIT SHALL BE STUBBED TO JUST ENTER HEADER FRAME 3" TO 4" FROM OPENING SIDE OF DOOR.

NOTES:

1. THIS INSTALLATION DETAIL SHALL BE UTILIZED FOR ALL SECURITY DOORS.
2. ALL ELECTRICAL AND DATA WIRING SHALL BE IN CONDUIT PER CSU STANDARDS.
3. DRAWING NOT TO SCALE.

<b>Colorado State University</b> FACILITIES PLANNING, DESIGN AND CONSTRUCTION STANDARDS		DRAWING: <b>A-1D</b>
DATE: 03/04/2021		OPENINGS DIV. 08
<b>DOUBLE DOOR WITH          ELECTRIC STRIKE PER LEAF</b>		

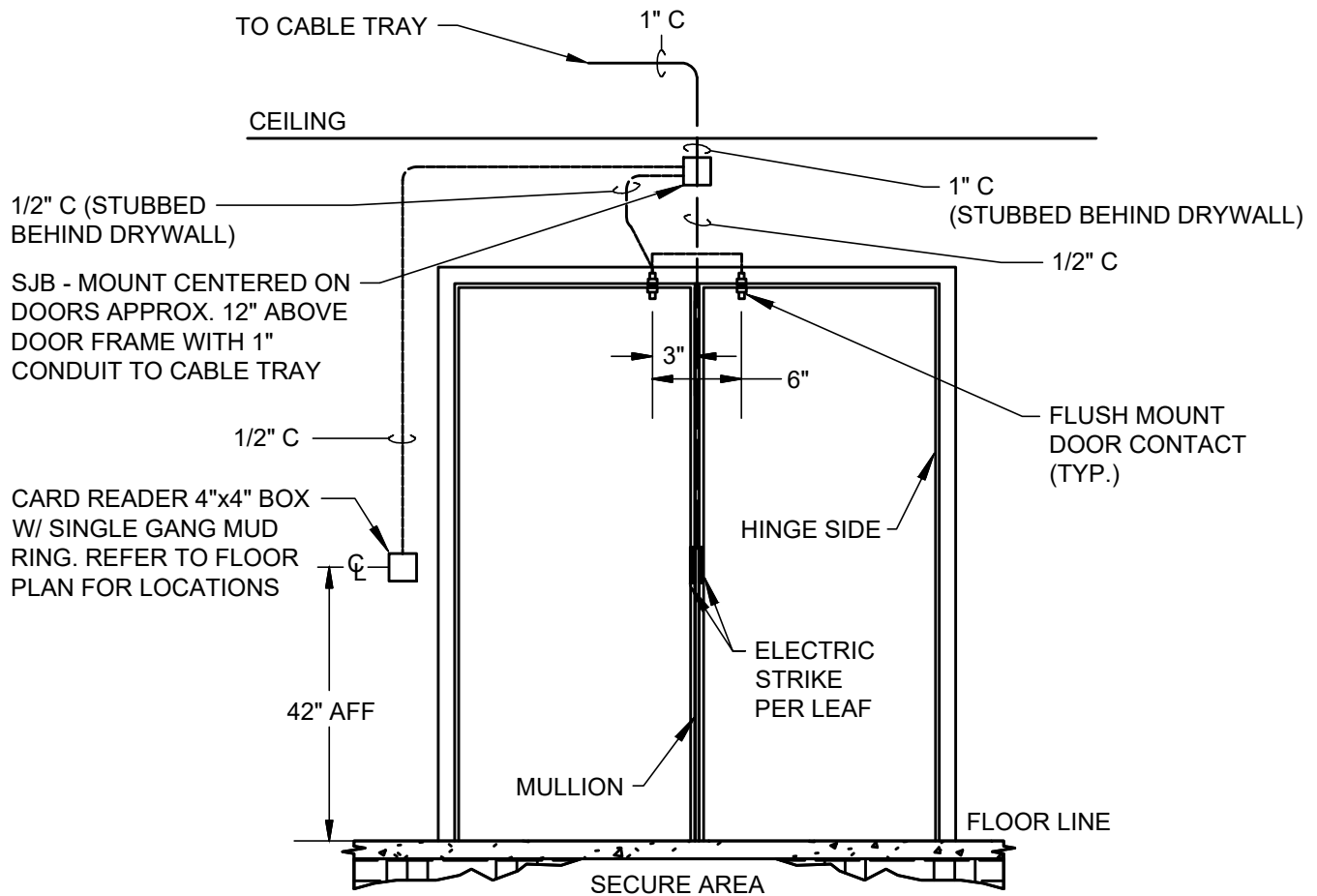

**NOTES:**

1. SECURITY JUNCTION BOX (SJB) SHALL BE 4x4 WITH SINGLE GANG MUD RING MOUNTED HORIZONTAL.
2. ALL INFRASTRUCTURE (ENCLOSURES, CONDUIT, ETC) TO BE PROVIDED BY CONTRACTOR.
3. DOOR HEADER CONDUIT SHALL BE STUBBED TO JUST ENTER HEADER FRAME 3" TO 4" FROM OPENING SIDE OF DOOR.

**NOTES:**

1. THIS INSTALLATION DETAIL SHALL BE UTILIZED FOR ALL SECURITY DOORS.
2. ALL ELECTRICAL AND DATA WIRING SHALL BE IN CONDUIT PER CSU STANDARDS.
3. DRAWING NOT TO SCALE.

<b>Colorado State University</b>		DRAWING:
FACILITIES PLANNING, DESIGN AND CONSTRUCTION STANDARDS		A-1E
DATE: 03/04/2021		OPENINGS DIV. 08
<b>DOUBLE DOOR WITH ELECTRIC STRIKE PER LEAF AND CARD READER</b>		

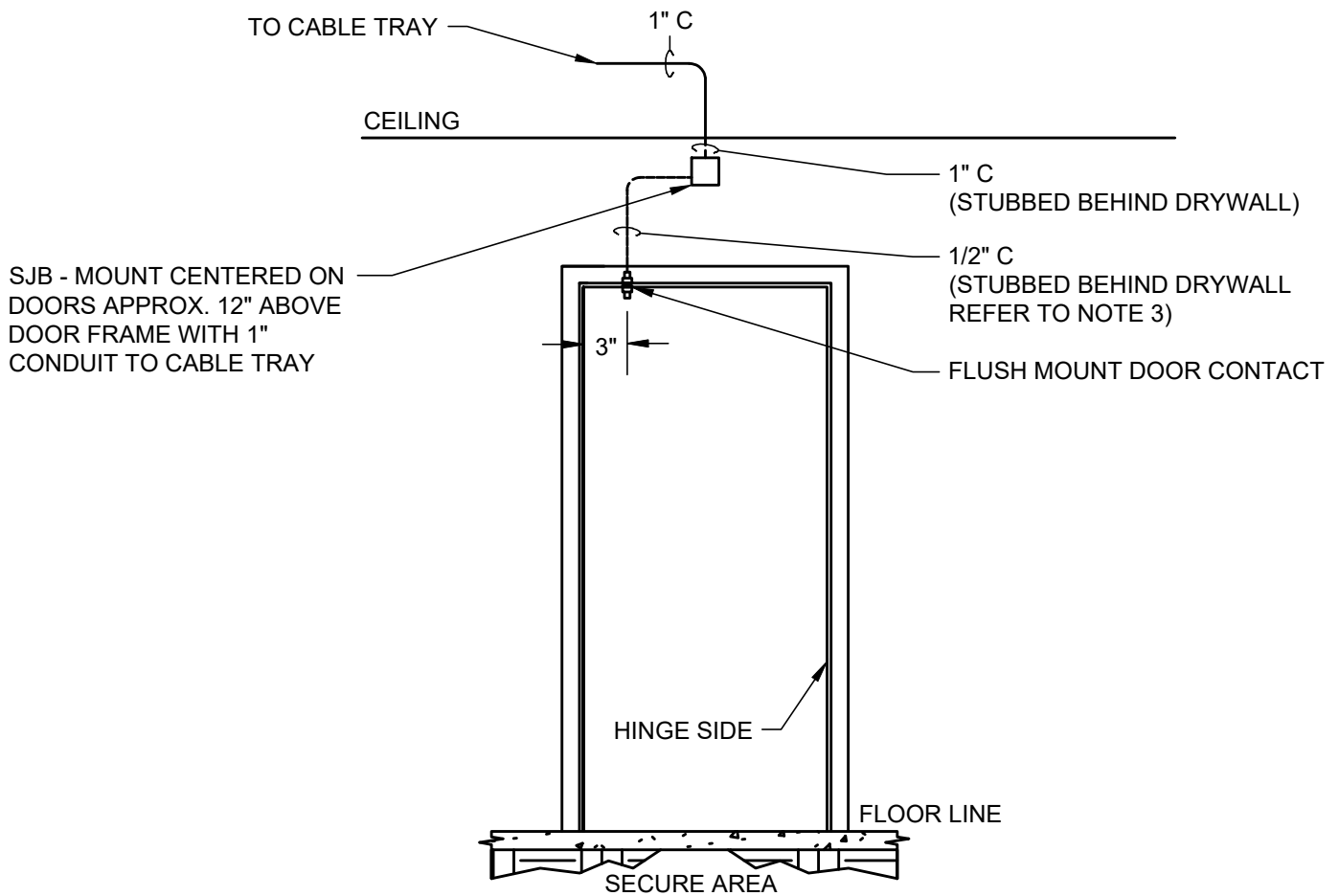

**NOTES:**

1. SECURITY JUNCTION BOX (SJB) SHALL BE 4x4 WITH SINGLE GANG MUD RING MOUNTED HORIZONTAL.
2. ALL INFRASTRUCTURE (ENCLOSURES, CONDUIT, ETC) TO BE PROVIDED BY CONTRACTOR.
3. DOOR HEADER CONDUIT SHALL BE STUBBED TO JUST ENTER HEADER FRAME 3" TO 4" FROM OPENING SIDE OF DOOR.

**NOTES:**

1. THIS INSTALLATION DETAIL SHALL BE UTILIZED FOR ALL SECURITY DOORS.
2. ALL ELECTRICAL AND DATA WIRING SHALL BE IN CONDUIT PER CSU STANDARDS.
3. DRAWING NOT TO SCALE.

<b>Colorado State University</b> FACILITIES PLANNING, DESIGN AND CONSTRUCTION STANDARDS	DRAWING: <b>A-1F</b>
	DATE: 03/04/2021 OPENINGS DIV. 08
<b>SINGLE DOOR</b>	

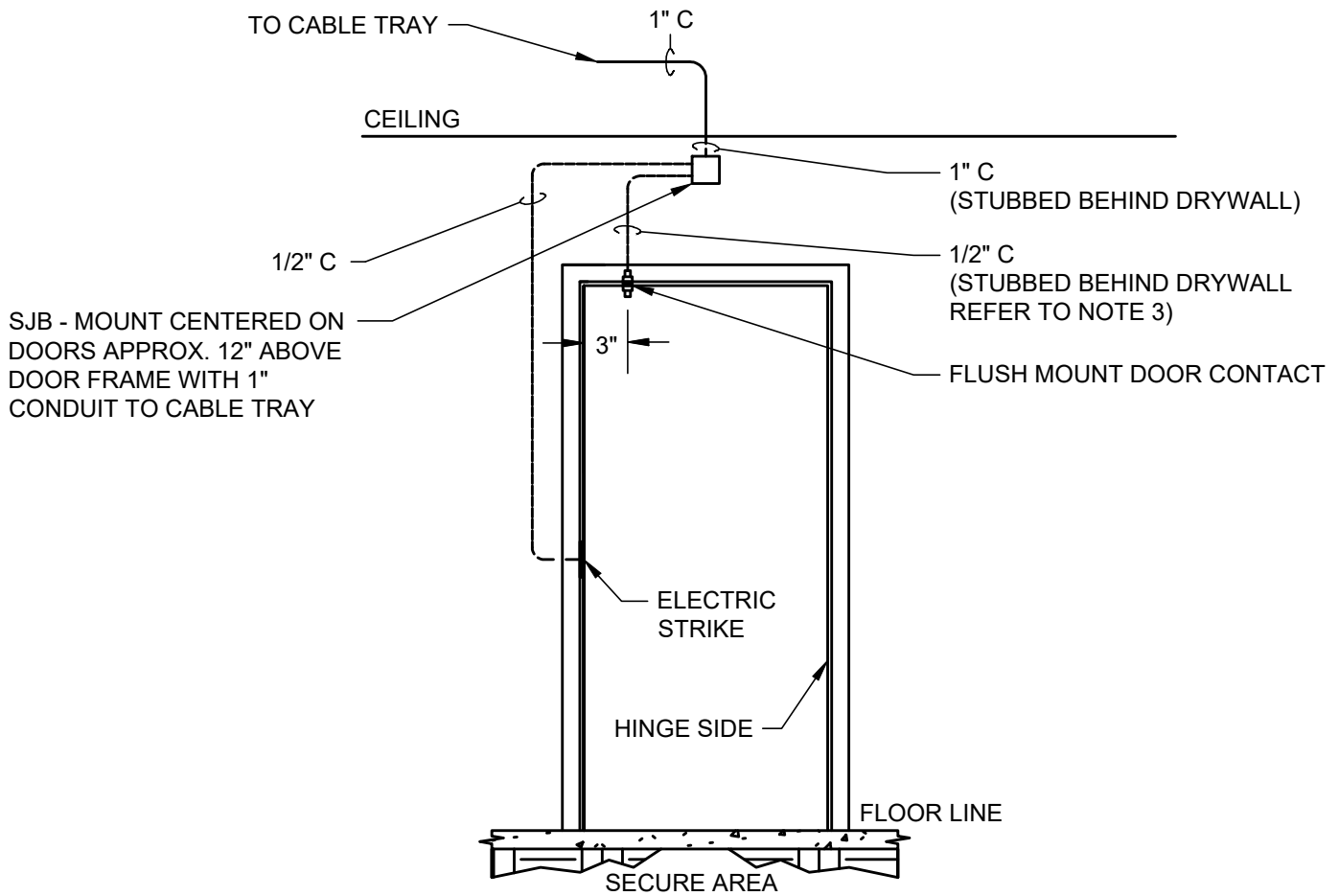

NOTES:

1. SECURITY JUNCTION BOX (SJB) SHALL BE 4x4 WITH SINGLE GANG MUD RING MOUNTED HORIZONTAL.
2. ALL INFRASTRUCTURE (ENCLOSURES, CONDUIT, ETC) TO BE PROVIDED BY CONTRACTOR.
3. DOOR HEADER CONDUIT SHALL BE STUBBED TO JUST ENTER HEADER FRAME 3" TO 4" FROM OPENING SIDE OF DOOR.

NOTES:

1. THIS INSTALLATION DETAIL SHALL BE UTILIZED FOR ALL SECURITY DOORS.
2. ALL ELECTRICAL AND DATA WIRING SHALL BE IN CONDUIT PER CSU STANDARDS.
3. DRAWING NOT TO SCALE.

<b>Colorado State University</b> FACILITIES PLANNING, DESIGN AND CONSTRUCTION STANDARDS	DRAWING: <b>A-1G</b>
	OPENINGS DIV. 08
DATE: 03/04/2021	
<b>SINGLE DOOR WITH ELECTRIC STRIKE</b>	

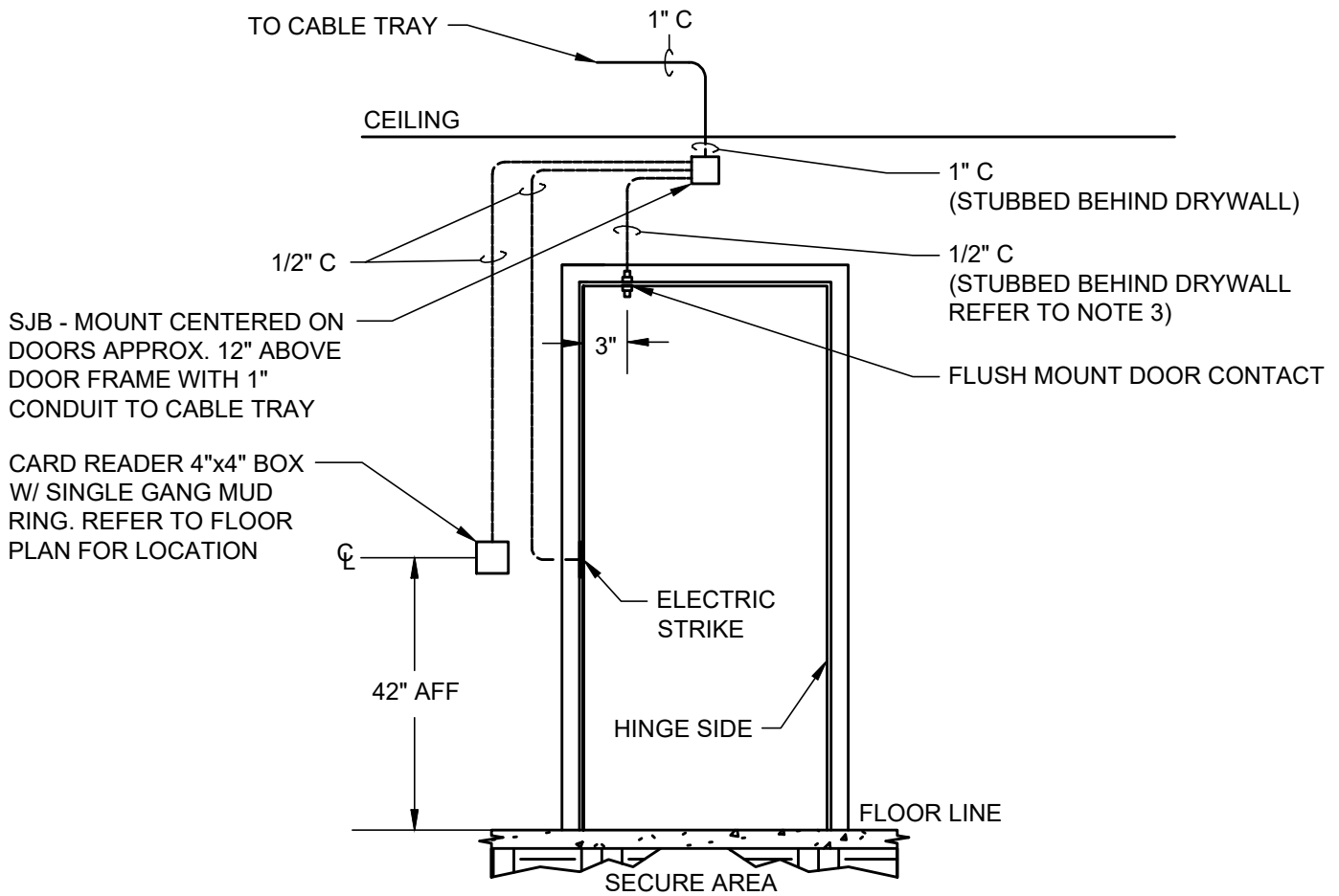

SJB - MOUNT CENTERED ON DOORS APPROX. 12" ABOVE DOOR FRAME WITH 1" CONDUIT TO CABLE TRAY

CARD READER 4"x4" BOX W/ SINGLE GANG MUD RING. REFER TO FLOOR PLAN FOR LOCATION

**NOTES:**

1. SECURITY JUNCTION BOX (SJB) SHALL BE 4x4 WITH SINGLE GANG MUD RING MOUNTED HORIZONTAL.
2. ALL INFRASTRUCTURE (ENCLOSURES, CONDUIT, ETC) TO BE PROVIDED BY CONTRACTOR.
3. DOOR HEADER CONDUIT SHALL BE STUBBED TO JUST ENTER HEADER FRAME 3" TO 4" FROM OPENING SIDE OF DOOR.

**NOTES:**

1. THIS INSTALLATION DETAIL SHALL BE UTILIZED FOR ALL SECURITY DOORS.
2. ALL ELECTRICAL AND DATA WIRING SHALL BE IN CONDUIT PER CSU STANDARDS.
3. DRAWING NOT TO SCALE.

<b>Colorado State University</b> FACILITIES PLANNING, DESIGN AND CONSTRUCTION STANDARDS		DRAWING: <b>A-1H</b>
DATE: 03/04/2021		OPENINGS DIV. 08
<b>SINGLE DOOR WITH ELECTRIC          STRIKE AND CARD READER</b>		



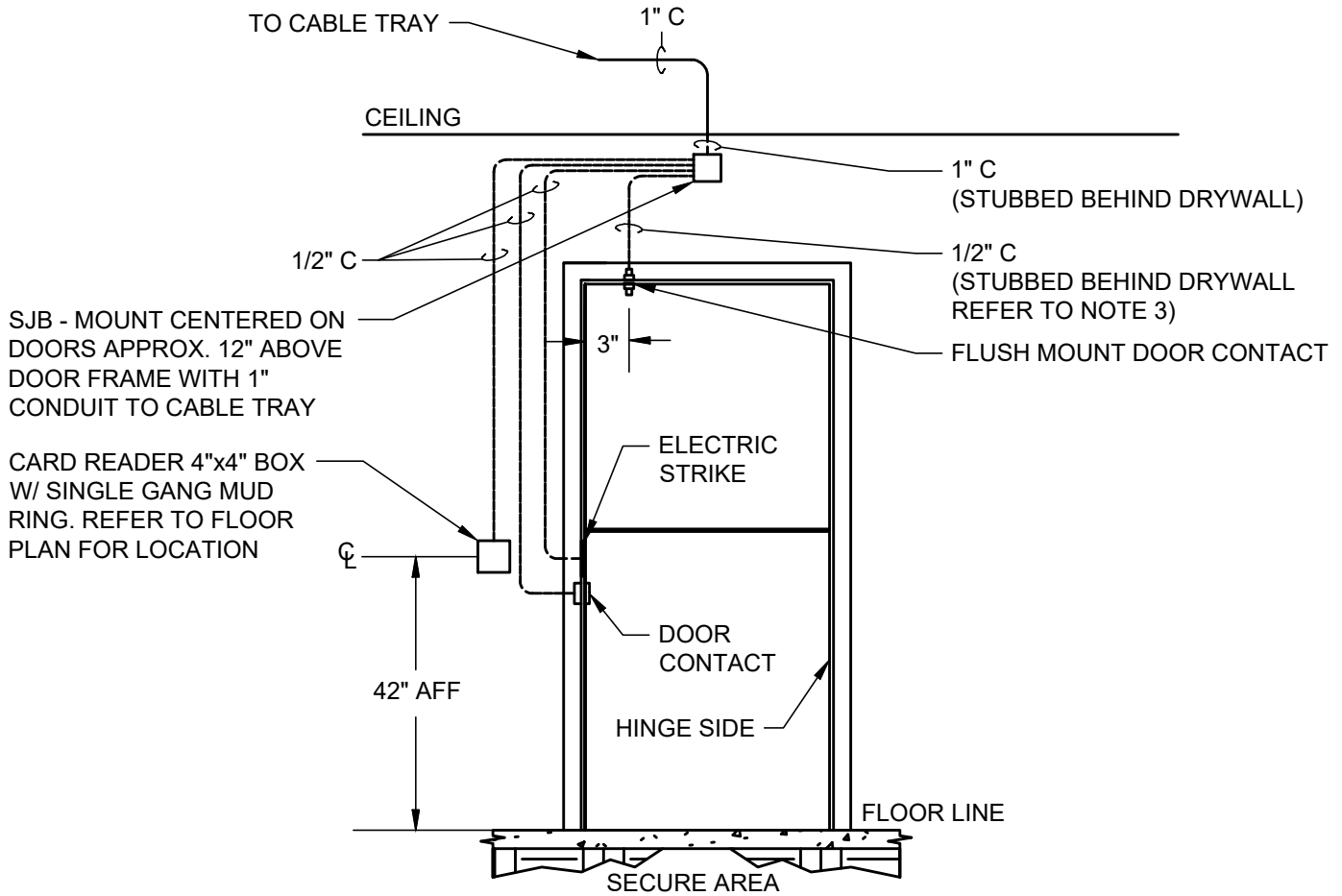

NOTES:

1. SECURITY JUNCTION BOX (SJB) SHALL BE 4x4 WITH SINGLE GANG MUD RING MOUNTED HORIZONTAL.
2. ALL INFRASTRUCTURE (ENCLOSURES, CONDUIT, ETC) TO BE PROVIDED BY CONTRACTOR.
3. DOOR HEADER CONDUIT SHALL BE STUBBED TO JUST ENTER HEADER FRAME 3" TO 4" FROM OPENING SIDE OF DOOR.

NOTES:

1. THIS INSTALLATION DETAIL SHALL BE UTILIZED FOR ALL SECURITY DOORS.
2. ALL ELECTRICAL AND DATA WIRING SHALL BE IN CONDUIT PER CSU STANDARDS.
3. DRAWING NOT TO SCALE.

<b>Colorado State University</b> FACILITIES PLANNING, DESIGN AND CONSTRUCTION STANDARDS	DRAWING: <b>A-11</b>
	OPENINGS DIV. 08
DATE: 03/04/2021	
SINGLE DUTCH DOOR WITH ELECTRIC STRIKE AND CARD READER	

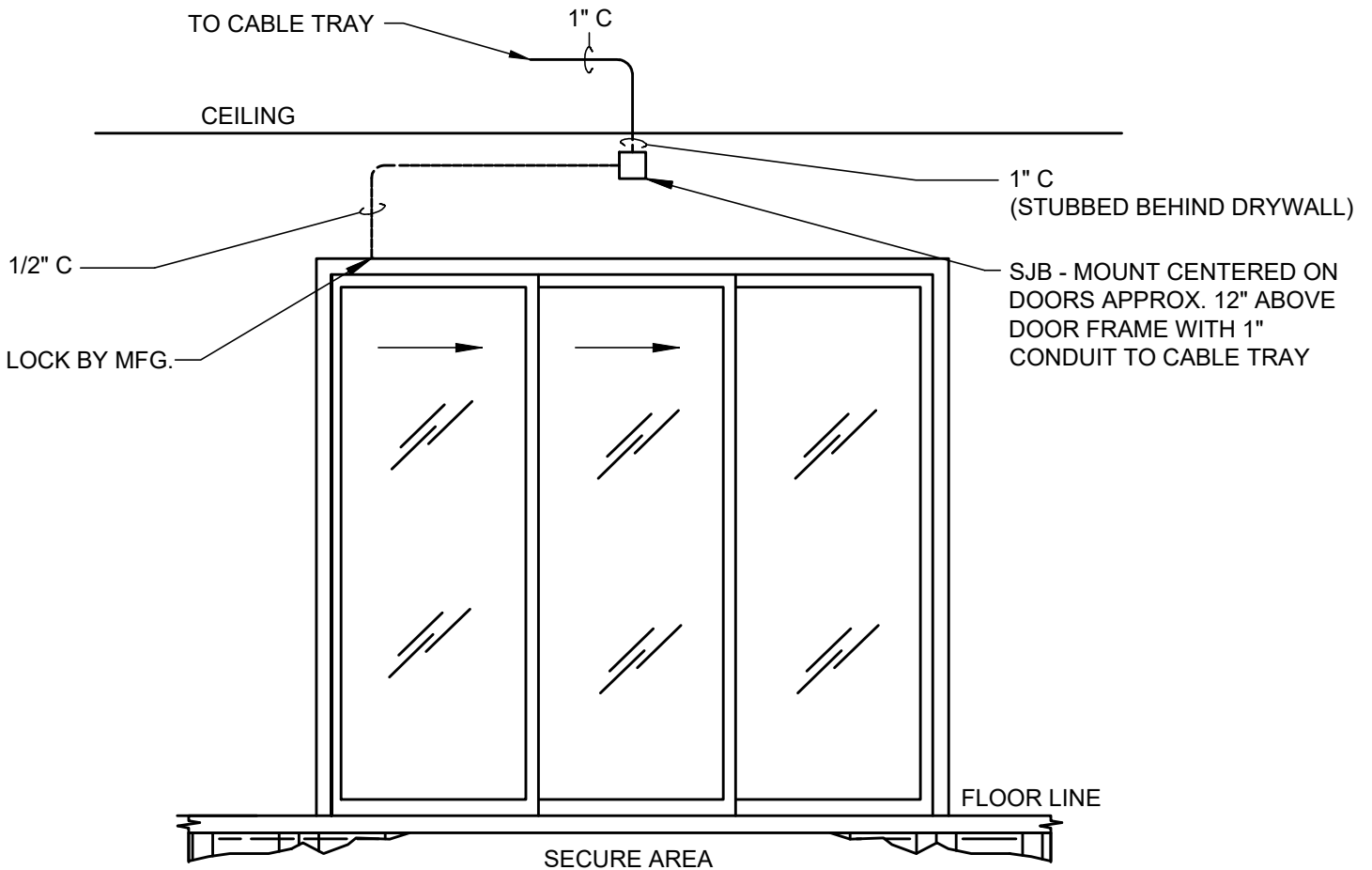

NOTES:

1. SECURITY JUNCTION BOX (SJB) SHALL BE 4x4 WITH SINGLE GANG MUD RING MOUNTED HORIZONTAL.
2. ALL INFRASTRUCTURE (ENCLOSURES, CONDUIT, ETC) TO BE PROVIDED BY CONTRACTOR.

NOTES:

1. THIS INSTALLATION DETAIL SHALL BE UTILIZED FOR ALL SECURITY DOORS.
2. ALL ELECTRICAL AND DATA WIRING SHALL BE IN CONDUIT PER CSU STANDARDS.
3. DRAWING NOT TO SCALE.

<b>Colorado State University</b>		DRAWING:
FACILITIES PLANNING, DESIGN AND CONSTRUCTION STANDARDS		A-1J
DATE: 03/04/2021		OPENINGS DIV. 08
<b>SLIDING DOOR</b>		